

# Hydro-pneumatic Handtool for Speed Fasteners

## 753 Model

### Features

- Average cycle time of less than 2 seconds
- High capacity, magazine fed fasteners
- Robust and durable construction
- Lightweight construction and zero actuation recoil
- Available with in-line handle and top or bottom hose configuration
- Low maintenance handtool
- Long life, self priming intensifier
- Long reach barrel

### Benefits

- Increased productivity
- Reduced component handling and subsequent spillage
- Reduced operator fatigue
- Optimised ergonomic performance for improved productivity
- Productive time is maximised
- Consistent actuation and hence joint formation
- Can be used in many difficult access applications

### Specifications

Weight (pistol only)	1.2 kg (2.6 lbs)
Pull Force @ 5.5 bar	3.89 kN (875lbf)
Stroke min.	30 mm (1.18ins)
Cycle Time	1.0 sec
Air Supply Pressure	5 – 7 bar
Free Air Volume @ 5.1 bar	2.6 litres
Noise Level	< 70 dB(A)
Vibration	< 2.5m/s <sup>2</sup>
Intensification ratio	32:1

### Placing capability

All Speed Fasteners from diameter 2.4 mm (3/32") to 6.4 mm (1/4").

For detailed information on placing capability and nose equipment please refer to the tool manual on our website [www.avdel-global.com](http://www.avdel-global.com) or contact your local Avdel representative.



### Dimensions (mm)

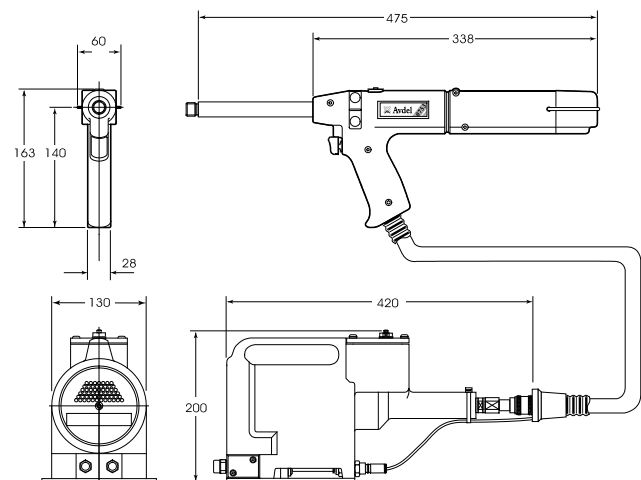

An Acument™ Global Technologies Company

[www.avdel-global.com](http://www.avdel-global.com)

Avdel UK Limited  
Pacific House, 2 Swiftfields  
Welwyn Garden City, Hertfordshire AL7 1LY  
Tel. +44 (0)1707 292-000 · Fax -199  
[enquiries@acument.com](mailto:enquiries@acument.com)

© 2007 Acument Intellectual Properties, LLC

04a.2007